



AUSTRALIAN MARITIME COLLEGE

FACULTY OF MARITIME TRANSPORT AND ENGINEERING

EXAMINATION

COURSE:	Bachelor of Engineering (Ocean Engineering) Bachelor of Engineering (Marine and Offshore Systems)
SUBJECT:	Instrumentation and Process Control
CODE:	E07 267
DATE:	2005
DAY:	
START TIME:	
END TIME:	
EXAMINER/s:	Hung Nguyen

MOBILE PHONES AND ELECTRONIC DICTIONARIES ARE STRICTLY PROHIBITED IN THE EXAMINATION VENUE	
THE FOLLOWING ARE PERMITTED AND REQUIRED FOR THIS EXAMINATION	
	Open Book
X	Calculator (Non-programmable)
	Calculator (Programmable)
	Graph paper
	Self Prepared Notes A4 sheet
X	Formula sheet

Note: Mark with an "X" the permitted items

INSTRUCTIONS TO CANDIDATES

Time allowed: 3 hours

Answer instructions: There are six (6) questions. Answer all questions.
You should read the questions very carefully before answering in order to avoid misunderstanding.
The mark for each question is indicated below each question.
There are total of 72 marks available in this examination.

Pass Level: You are required to achieve over 50% of the possible marks for this examination before you can be considered for a grade of pass or better.

The minimum mark to be eligible for a resit examination is 30% overall (X marks out of X)

Note:

In order to ensure that the examiner is aware of your entire examination returns, please ensure that:

- *Your student I.D. number is entered clearly and legibly on all examination answer booklets that you use.*
- *You indicate which questions are answered in each booklet.*
- *All answer booklets are sequentially numbered in the box provided on the front page of each booklet.*
- *The total number of booklets that you use is also indicated in the box provided on the front page of each booklet.*

QUESTION 1

(a) Describe the general block diagram of a measuring system and state the functions of each block. [2 marks]

(b) Describe a type of transducer (operating principle, simple structure, range of output, and advantages and disadvantages) you have known the best. [4 marks]

(c) A piezo-electric transducer used to measure pressure has a sensitivity of $4.5\text{mV}/\text{bar}$ and an output impedance of $250\ \Omega$. The transducer is connected to a galvanometer of resistance $50\ \Omega$ having a sensitivity of $10\text{mm}/\mu\text{A}$ as shown in the following figure. The piezo-electric transducer has a constant error of $+0.025\text{mV}$ in its range and the galvanometer has a constant error of $+1.25\text{mm}$ in its range. The galvanometer spot deflection is 80mm on the ultra-violet sensitive paper.

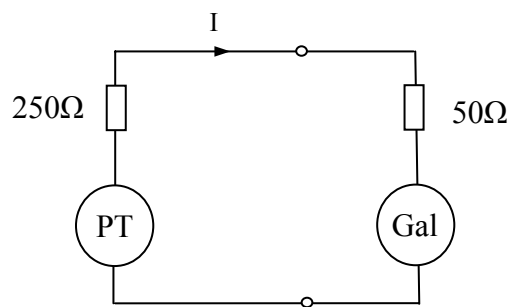

- (i) Calculate the percentage error (%) of the galvanometer at the reading of spot deflection of the above value.
- (ii) Calculate the percentage error (%) of the transducer at reading of output voltage corresponding to the spot deflection of the above value.
- (iii) Calculate the maximum possible error and probable possible error of the whole system.
- (iv) Calculate the input pressure to be measured.

[1+2+1+2 marks]

QUESTION 2

(a) Describe the general block diagram of a control system and state the functions of each block. [2 marks]

(b) Describe a final control element (actuator) (including operating principle, simple structure, features) you have known the best. [4 Marks]

(c) Consider the tank system shown in the following figure with an inflow q_i (rate of volume flow). The cross-sectional area of the tank is constant and equal to A . Write a differential equation in terms of water level (y in meter) for this system.

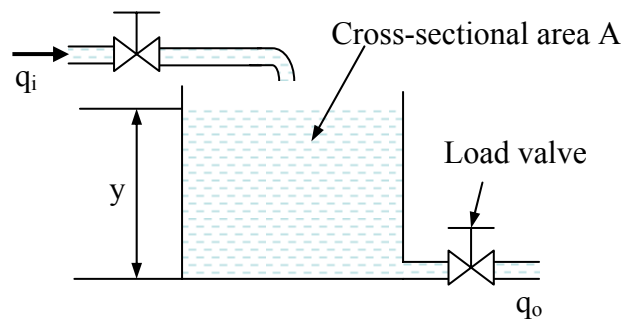

Write the transfer function, assuming that the tank starts off empty. The inflow q_i of the tank system is adjusted by a pump that has transfer function $\frac{4}{s+2}$ and the pump is controlled by a PI controller with control gains K_p and K_I , respectively. The feedback signal (water level) is measured by a level detector that has gain $K = 5$. Draw a block diagram for the whole control system and write the total closed-loop transfer function.

[6 marks]

QUESTION 3

(a) Define the transfer function for continuous-time systems, its poles and zeros. Give an example to illustrate your answers.

[2 marks]

(b) A system is characterized by the following differential equation:

$$\frac{1}{b} \ddot{y} + a\dot{y} + by = cu$$

where u is input, y is output, a , b and c are constants. Find the transfer function, assuming all initial conditions are zero, find poles and zeros of the transfer function. Describe the system response if $a = 1$, $b = 5$ and $c = 7$. Find a value of a to ensure that the response is not oscillatory.

[4 marks]

(c) The following block diagram describes a PID control system (consisting of process block, feedback signal transducer block, comparison block and PID controller block).

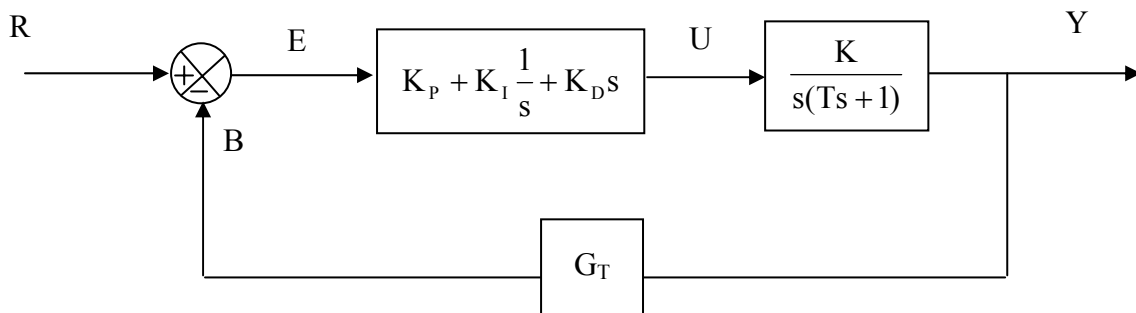

where R is set point, E is error, Y is output (process variable), U is input, B is feedback signal, K_p , K_i and K_d are control gains, T and K are constants, G_T is transducer gain (constant). Write the open-loop transfer function, and the total feedback transfer function.

[6 marks]

QUESTION 4

(a) State the steady state error of a control system. Using the final value theorem, show how to calculate the steady state error.

[3 marks]

(b) Given a second-order system as follows:

$$\ddot{y} + 2\omega_n \xi \dot{y} + \omega_n^2 y = ku$$

where y and u are output and input, ω_n is undamped natural frequency, ξ is damping ratio and k is a constant. Write transfer function and find its poles and zeros. Find the steady state errors for the following cases:

(i) $\omega_n = 1.2$ rad/sec, $\xi = 0.7$ and $k = \omega_n^2$ and unit step input signal

(ii) $\omega_n = 1.2$ rad/sec, $\xi = 0.7$ and $k = \omega_n^2$ and a unit ramp input signal

[3 marks]

(c) State the open-loop control and closed-loop control systems. What are the differences between the open-loop and closed-loop control systems?

[3 marks]

(d) A marine engine has a transfer function of $\frac{1}{s(s+6)}$ at 120rpm, where the input is fuel

flow rate and the output is rotational speed. The fuel valve is controlled with a d.c. motor which has a transfer function of $\frac{1}{s+2}$, where the input is voltage and the output is fuel

flow rate. A PID controller is implemented for the motor with control gains of K_P , K_I and K_D , respectively. A tachometer in the feedback loop measures the rotational speed and feeds back with a gain of 6. Draw the system block diagram and calculate the total feedback transfer function.

At the lower speed of 80rpm the engine transfer function is $\frac{1}{s(s+3)}$. Calculate the total feedback transfer function if the engine runs at 80rpm.

[3 marks]

QUESTION 5

(a) Describe a control system in marine and offshore industry, including simple structure, operating principle, features. [Hints: You may use block diagram or schematic diagram or formulae to illustrate your answers].

[6 marks]

(b) Find poles and zeros of the following transfer functions and draw them in the s-plane:

(i) $\frac{s^2 + 3s + 1}{(s + 3)(s^2 + 5s + 8)}$

(ii) $\frac{(s + 2)K}{(7.5s + 1)(3s^2 + 7s + 20)}$

[3 marks]

(c) Confirm that the following block diagram

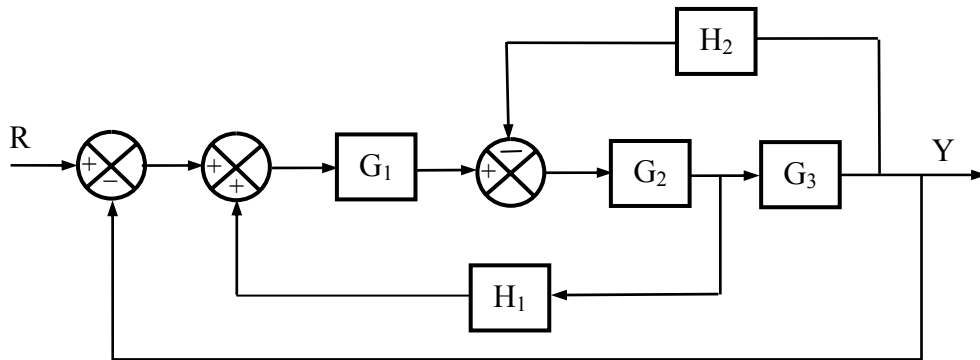

is equivalent to the following contracted block diagram.

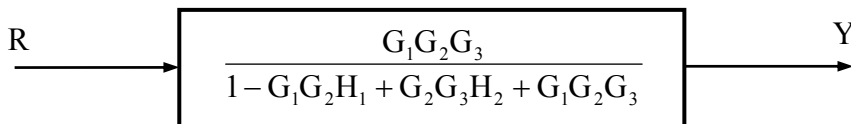

[3 marks]

QUESTION 6

(a) Define velocities (linear velocity and angular velocity) and their units. List the methods of measuring velocity.

[2 marks]

(b) State the Doppler principle (Doppler shift). How can the Doppler principle be applied in instrumentation and process control engineering?

[4 marks]

(c) Calculate the frequencies of cyclic waves that have periodic times (period) of (i) 2.5s, (ii) 45ms, and (iii) 20 μ s, and the periodic times of square waves that have frequencies of (iv) 50Hz, (v) 2.5kHz, and (vi) 30MHz.

[3 marks]

(d) A U-tube mercury manometer and an orifice plate are applied in measurement of weight of oil flowing through a pipe in an offshore production system as shown in the following figure. The pipe has the internal diameter of 10cm, and a constant k of 1.5. The difference in the mercury levels in the two legs is 60mm. The oil density is 800kg/m³, and mercury density is 13.56 \times 10³kg/m³.

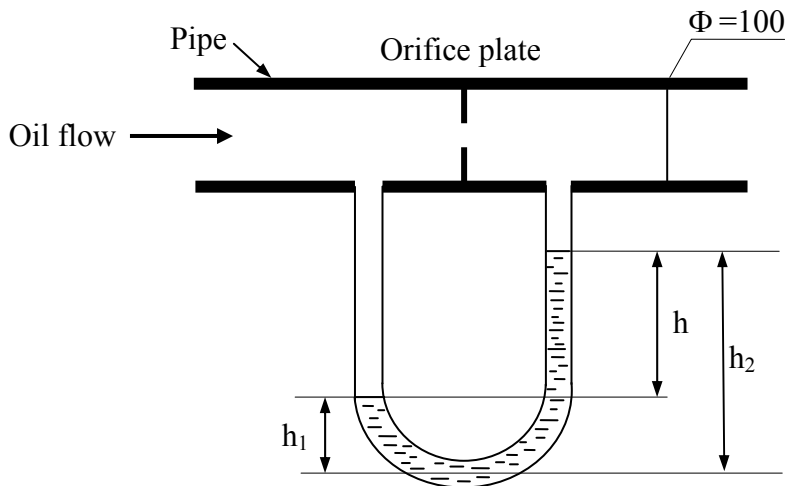

Calculate:

- (i) Differential pressure
- (ii) Volumetric flow of oil in the pipe.
- (iii) Mass of oil flowing through the pipe for one day.

[1+1+1 marks]