

JEE326 Instrumentation and Process Control

Week 1

Unit Outline

Chapter 1 Introduction to Inst and PC

By Dr. Hung Nguyen
Department of Maritime Engineering

Main Topics

- Unit Outline (updated version):
 - Unit description/Learning outcomes
 - Contents/theory and practical
 - Assessment information
- Chapter 1 An Introduction to Instrumentation and Process Control

Unit Outline

- Unit description:
 - fundamentals of instrumentation, methods of common measurement in marine and offshore industry
 - basic control theory: how a control system work to maintain a quantity as desired
- Learning Outcomes:
 - (p.2 Unit Outline)

Unit Outline

- Fundamentals of instrumentation
 - Basic principles of transducers/sensors
 - Standard drawing symbols
 - Signal conditioning, temperature, pressure, flow, level, density, viscosity
 - Actuators and final control elements
- Basic control engineering
 - On/Off control, P, PI, PD, PID control
 - Types of controllers (pneumatic, hydraulic, elec)
- Labs: operation of PC-based M.S. & controllers

Unit Outline

- Learning resources/Textbooks: Lecture Notes
- Recommended textbook:
 - Johnson, C.D. (2006). *Process Control Instrumentation Technology*. Pearson Education.
- References:
 - Anderson, N.A., *Instrumentation for Processes Measurement and Control*, CRC Press, Boca Raton, Florida, USA, 1998.
 - Ogata, K., *Modern Control Engineering*, 4th Ed., Prentice-Hall Inc., New Jersey, 2004.

Unit Outline

- E-learning resources
 - <http://www.utas.edu.au/coursesonline/>
 - Lecturer's website:
<http://academic.amc.edu.au/~hnguyen>

Unit Outline

- Class time (updated timetable on 14/9/09):

Class	Day	Time	Location	Group
Lecture	Mon	3:10-5:00	G47	All
Lecture	Wed	12:00-1:00	G80	All
Tutorial	Wed	1:00-2:00	G80	All
Labs	Thu	9:00-11:00 (starts wk 5)	G51 (Control Lab)	TBA

- **Complementary lecture:** 9:00-11:00 am Thursday 23rd 7 in G79

Unit Outline

- Syllabus and Schedule
– (see the updated Unit Outline)

Unit Outline

- Assessment information:
 - Class Test 1 (15%): Week 7 Mon 24.8.09
 - Class Test 2 (15%): Week 11 Mon 28.9.09
 - Tutorials (5%): a tutorial notebook is required -> submit at the end of semester
 - Practicals/Labs (15%): TBA (from Week 5) Due date of submission 2 weeks after commencing
 - Exam (50%): TBA

Any Questions?



Chapter 1 Introduction

- Learning Outcomes:
 - Process control
 - Instrumentation
 - Basic concepts: system, process, open-loop, closed-loop
 - Basic components of a measuring system and a control system
- Reading: Chapter 1

Chapter 1 Introduction

- Process control
 - Process: relationship between physical variables
 - Example 1.1

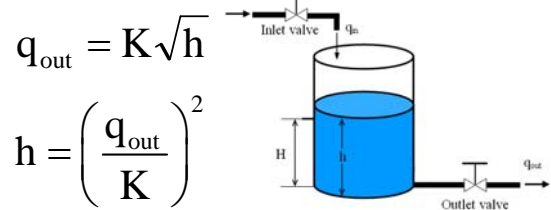

Figure 1.1 The liquid tank system

Chapter 1 Introduction

- **Human aided control vs Automatic control**

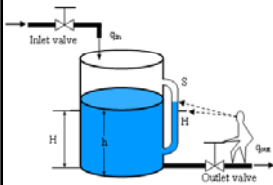

Figure 1.2 Human-aided process control

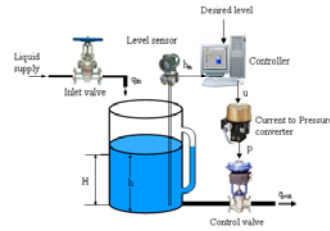

Figure 1.3 Automatic process control

Chapter 1 Introduction

- Instrumentation
 - Inventory
 - Quantity management
 - Statistical analysis
 - Test, indication etc.
- Example
 - Tank system
- Overview of history

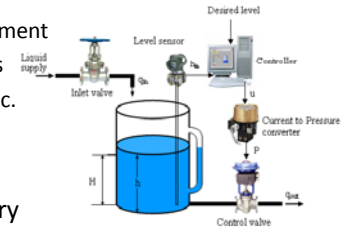

Figure 1.3 Automatic process control

Chapter 1 Introduction

- **Basic concepts:**

- System

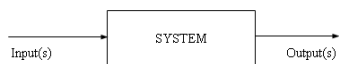

Figure 1.4 Concept of a system

- Signals and Variables

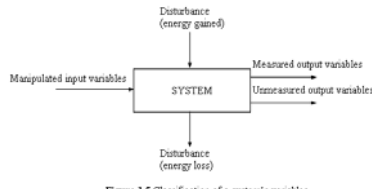

Figure 1.5 Classification of a system's variables

Chapter 1 Introduction

- Example: Variables of a stirred tank

Input variables?

Output variables?

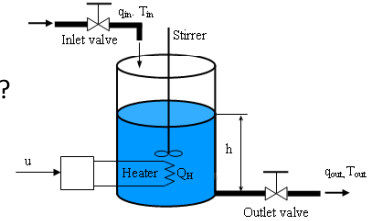

Figure 1.6 The liquid tank system

Chapter 1 Introduction

- **Block diagram**

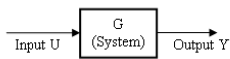

Figure 1.7 Block representation of a system

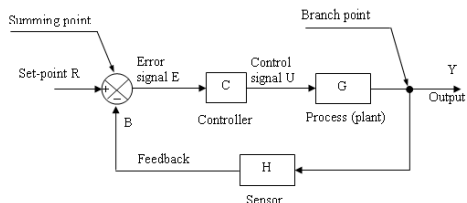

Figure 1.8 Block diagram of a control system

Chapter 1 Introduction

- **Open-loop system:**
 - No feedback

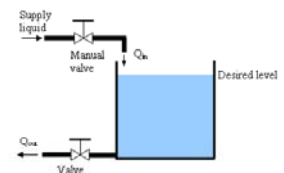

Figure 1.9 Open loop level control system

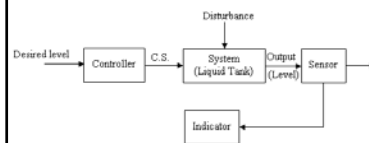

Figure 1.10 Block diagram of an open-loop system

Chapter 1 Introduction

- Closed-loop system
 - Feedback signal
 - Comparison of measured OP with Desired Value
- An illustration of closed-loop control principle

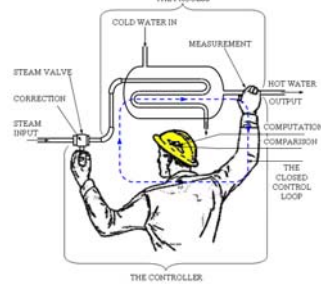

Figure 1.11 An illustration of a heat exchanger when under manual control. The controller and process together form a closed loop of control (represented by the heavy dashed line)

Chapter 1

- Closed-loop system
 - Feedback signal

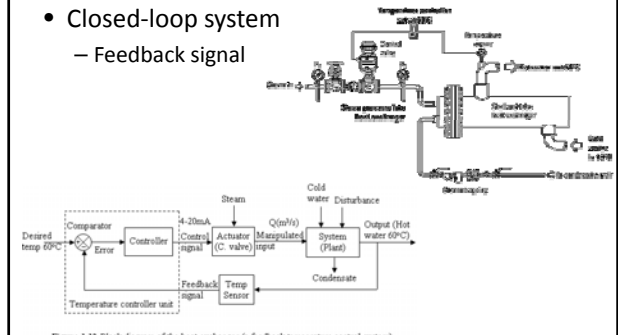

Figure 1.13 Block diagram of the heat exchanger (a feedback temperature control system)

Chapter 1 Introduction

- Basic components & signals: very complicated control system (e.g. spaceship) can be simplified as the following figure

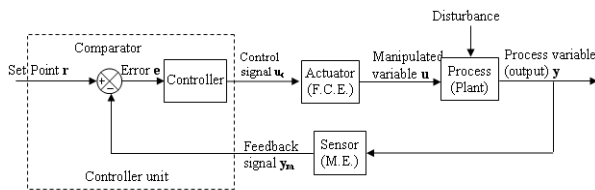

Figure 1.14 Basic components and signals of a feedback control system

Chapter 1 Introduction

- Feedback level control system

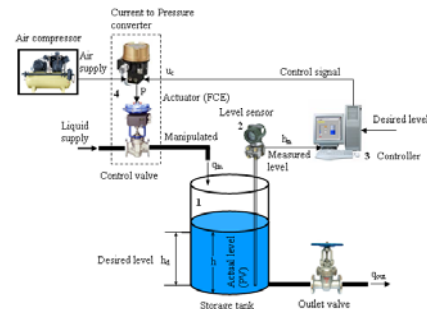

Figure 1.15 Schematic diagram of a feedback level control system

Chapter 1 Introduction

- Closed-loop system and energy conversion

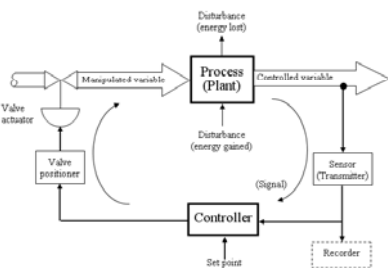

Figure 1.16 Closed loop control system and energy conversion

Chapter 1 Introduction

- Block diagram showing loop and signal processing

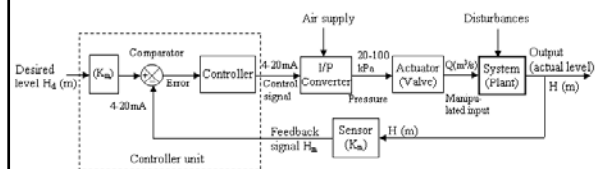

Figure 1.17 Block diagram of the feedback level control system

Chapter 1 Introduction

- Flow diagram using standard symbols

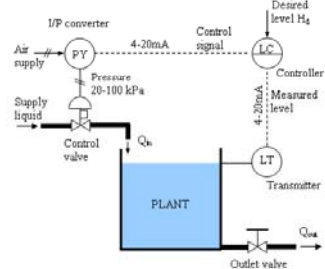

Figure 1.18 Flow diagram (using standard symbols) of a feedback process control system

Chapter 1 Introduction

Control Media

- Electrical
 - Hydraulic
 - Pneumatic
 - Thermal
 - Mechanical
- Most common:
combined

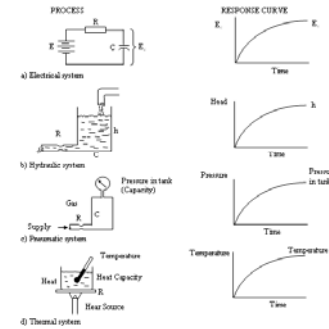
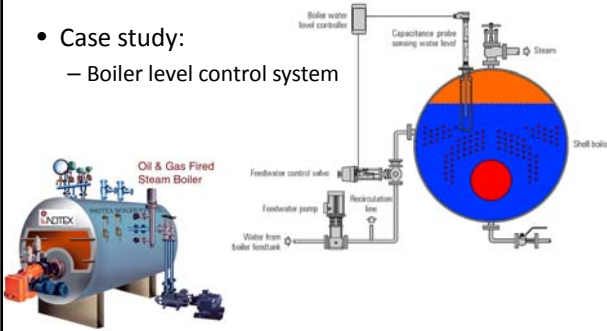

Figure 1.19 Four types of physical system: (a) electrical, (b) hydraulic, (c) pneumatic and (d) thermal. Each has a single capacity and single resistance and all have identical response characteristics (Anderson, 1980).

Chapter 1 Introduction

- Case study:
– Boiler level control system



Chapter 1 Introduction

- Case study: Ship and autopilot

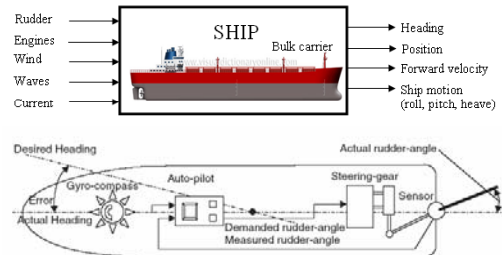

Figure 1.23 Ship autopilot control system

Chapter 1 Introduction

- Case study: Ship and autopilot

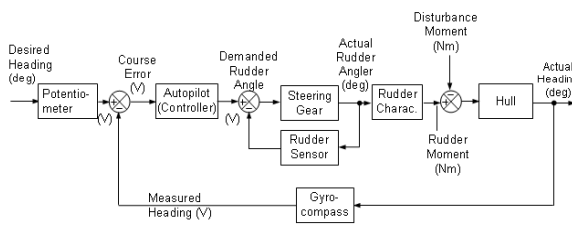

Figure 1.24 Block diagram of ship autopilot control system

Chapter 1 Introduction

- Stirred tank with level and temperature controls

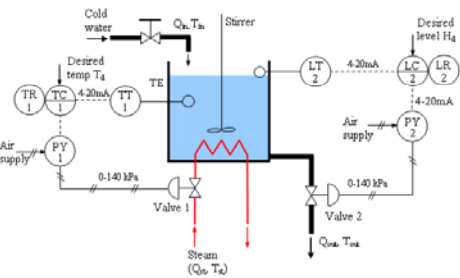
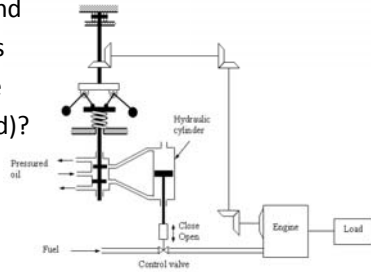

Figure 1.25 Process control systems for a stirred tank

Chapter 1 Introduction

- James Watt's Governor (marine governor)
- Identify input and
- output variables
- Process variable
- (to be controlled)?
- Manipulated
- variable?



Chapter 1 Introduction

- Summary:
 - Basic terms: process control, instrumentation
 - Historical overview
 - Functional block diagram
 - Open-loop, closed-loop systems
 - Basic components and signals
 - Examples of control systems

Any Questions?

