

## Tutorial 6 Chapter 13 Basic Control Theory

### Summary of Basic Control Theory

#### 1. Proportional Control – Gain and Proportional Band

##### 1.1 Error Calculations - % Span Error:

$$\text{Error} = \text{SP} - \text{PV}$$

$$\% \text{ Span Error} = \frac{\text{SP} - \text{PV}}{\text{Span}} 100\%$$

where Span = Maximum PV – Minimum PV. It should be noted that in some controllers, the Error is computed as Error = PV – SP, therefore the % Span Error is as:

$$\% \text{ Span Error} = \frac{\text{PV} - \text{SP}}{\text{Span}} 100\%$$

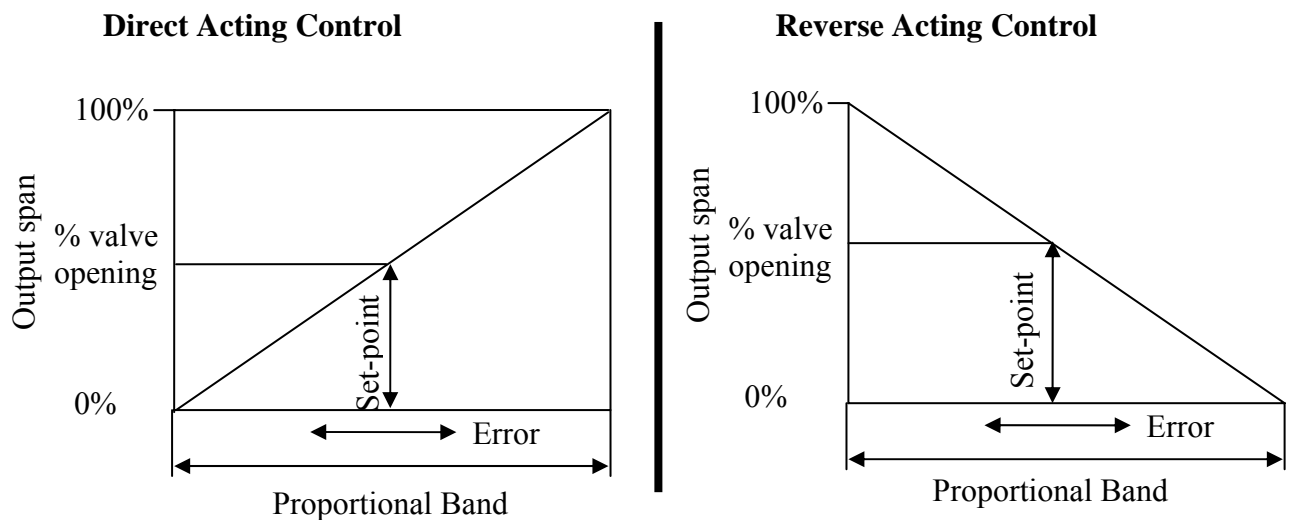

##### 1.2 Proportional Control

SP = Set Point

PV = Process Variable

$E = \text{SP} - \text{PV}$  (in some controllers,  $E = \text{PV} - \text{SP}$ ).

If  $\text{PV} > \text{SP}$  then E is negative

If  $\text{PV} < \text{SP}$  then E is positive

u = Controller Signal Output

$$\Delta u = u_{\text{final}} - u_{\text{initial}}$$

$K_p$  = Gain (Proportional Gain)

The Controller uses  $E = \text{SP} - \text{PV}$ . Then  $K_p$  is negative for Direct Acting,  $K_p$  is positive for Reverse Acting

PB = Proportional Band

Small (narrow) PB = High Gain

Large (wide) PB = Low Gain

$$K_p = \frac{100\%}{PB} = \frac{\Delta u}{\Delta e} = \frac{\Delta \text{Output}}{\Delta \text{Input}}$$

Proportional Control Signal:

$$u = K_p E$$

In some controllers the P control signal is computed as:

$$u = K_p E + B \text{ (where B is bias)}$$

Using the % span error we have:

$$u(\%) = \pm K_p \times (\% \text{ Span Error}) + B(\%)$$

**Example 1.1** A controller is capable of controlling temperature between  $-32^\circ\text{C}$  and  $+5^\circ\text{C}$  and has a set-point of  $-10^\circ\text{C}$ . Calculate the % span error when the PV is  $-8^\circ\text{C}$ .

**Solution**

Span =  $37^\circ\text{C}$ , so

$$\% \text{ Span Error} = \frac{-8 - (-10)}{37} \times 100\% = \frac{2}{37} \times 100\% = 5.41\% [(-8 - (-10))/37]$$

**Example 1.2** A controller has a stated % Span Error range of  $\pm 2\%$  and a range of  $500^\circ\text{C}$  to  $1500^\circ\text{C}$ . Calculate the possible range of the PV when the set-point is  $1000^\circ\text{C}$ .

**Solution**

The span =  $1500^\circ\text{C} - 500^\circ\text{C} = 1000^\circ\text{C}$

2% of span =  $2\% \times 1000^\circ\text{C} = 20^\circ\text{C}$

So the range of PV =  $(1000 - 20)^\circ\text{C}$  to  $(1000 + 20)^\circ\text{C} = 980^\circ\text{C}$  to  $1020^\circ\text{C}$

**Example 1.3** Valve "A" of the system shown in the following figure is linear with 10 cubic metre/hour flow for each percent controller output. The controller output is nominally 50% at set-point and  $K_p = 10$ . A load change occurs when flow through valve "B" changes from 500 cubic metre/hour to 600 cubic metre/hour. Calculate the new controller output and offset error.

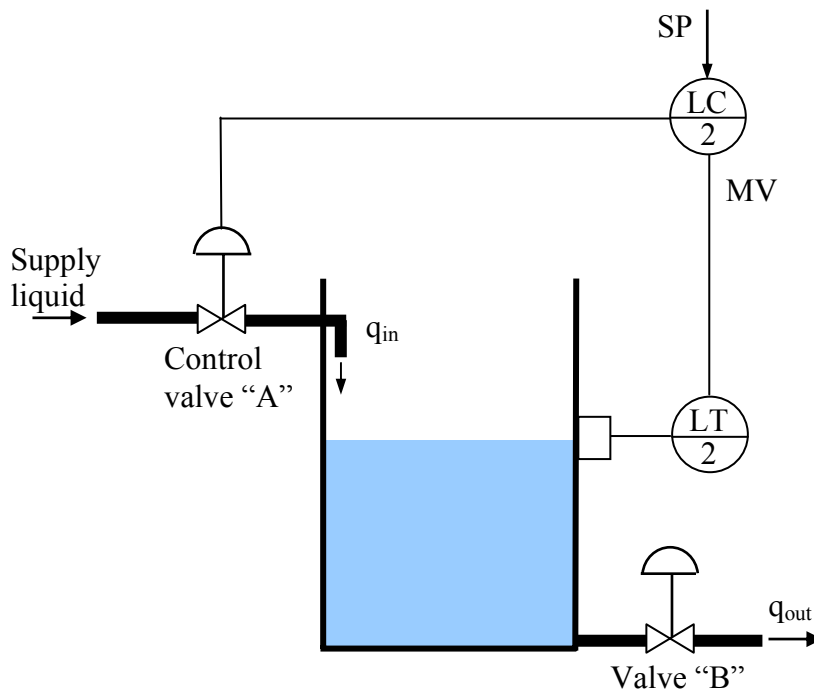

**Solution**

For this system to balance the inflow must equal the outflow, i.e.

$$\text{Inflow} = 600 \frac{\text{m}^3}{\text{h}}$$

$$\text{Outflow} = 600 \frac{\text{m}^3}{\text{hr}}$$

Therefore Valve position =  $\frac{600}{10} = 60\%$  OPEN = controller output

The equation for the controller is  $u = K_p E + u_0 = 10E + 50$  with  $u = 60\%$ :

$$60 = 10E + 50$$

Therefore:  $E = 1\%$  offset error.

**Example 1.4** A reverse acting Proportional Controller is adjusted to a Proportional Band of 80%. In the steady state before a disturbance, the input to the controller is 60 kPa and this value corresponds to the Set Point, while the output of the controller is 80 kPa. After a load change, the output of the controller in the resulting steady state is noted to have settled at 40 kPa. Determine the amount of ‘Offset’ that will result from the load change.

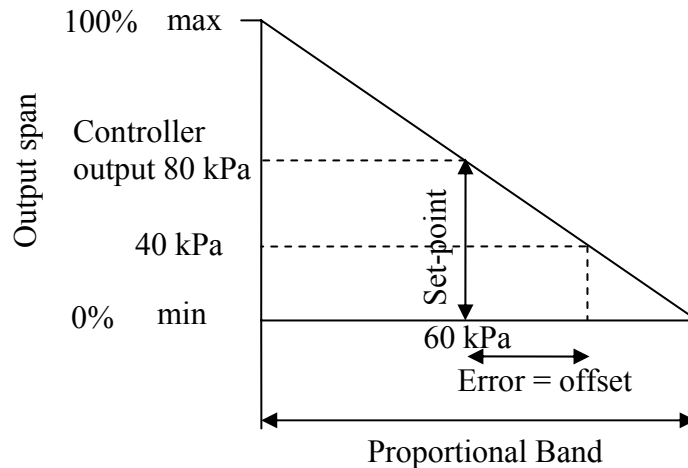

The change in controller output =  $40 \text{ kPa} - 80 \text{ kPa} = -40 \text{ kPa}$

The Proportional gain  $K_p = \frac{100\%}{\text{PB}} = \frac{100\%}{80\%} = 1.25 \text{ [kPa/kPa]}$

The Error in steady state = Offset =  $\epsilon = \frac{-40\text{kPa}}{1.25} = -32 \text{ kPa}$

**Example 1.5** A gas furnace (heating control-reverse control action) requires  $u_0 = 55\%$  to maintain a set point temperature of  $450^\circ\text{C}$ . The controller’s range is from  $200^\circ\text{C}$  to  $1000^\circ\text{C}$ . The Proportional Band is set to 12%. Calculate the upper and lower temperature limits for the proportional band.

**Solution:**

First calculate the proportional gain  $K_p = 100/\text{PB} = 100/12 = 8.33$

Use the formulas:  $u = \pm K_p \times \% \text{ span error} + u_0$  and find the % span error:

$$\% \text{ span error} = -\frac{u - u_0}{K_p}$$

$$\text{When } u = 100\% \text{ (fully ON) } \% \text{ span error} = -\frac{u - u_0}{K_p} = -\frac{100\% - 55\%}{8.33} = -5.4\%$$

$$\text{When } u = 0\% \text{ (fully OFF) } \% \text{ span error} = -\frac{u - u_0}{K_p} = -\frac{0\% - 55\%}{8.33} = +6.6\%$$

We now need to find the PV that corresponds to the upper and lower limits of the proportional band.

Use the formula:

$$\% \text{ span error} = \frac{PV - SP}{SPAN} \times 100\% \text{ and solve for PV}$$

$$PV = \frac{\% \text{ SPAN ERROR} \times SPAN}{100\%} + SP$$

$$\text{When } u = 100\% \text{ (fully ON) } PV = \frac{-5.4\% \times 800}{100\%} + 450 = 406.8^\circ\text{C}$$

$$\text{When } u = 0\% \text{ (fully OFF) } PV = \frac{+6.6\% \times 800}{100\%} + 450 = 502.8^\circ\text{C}$$

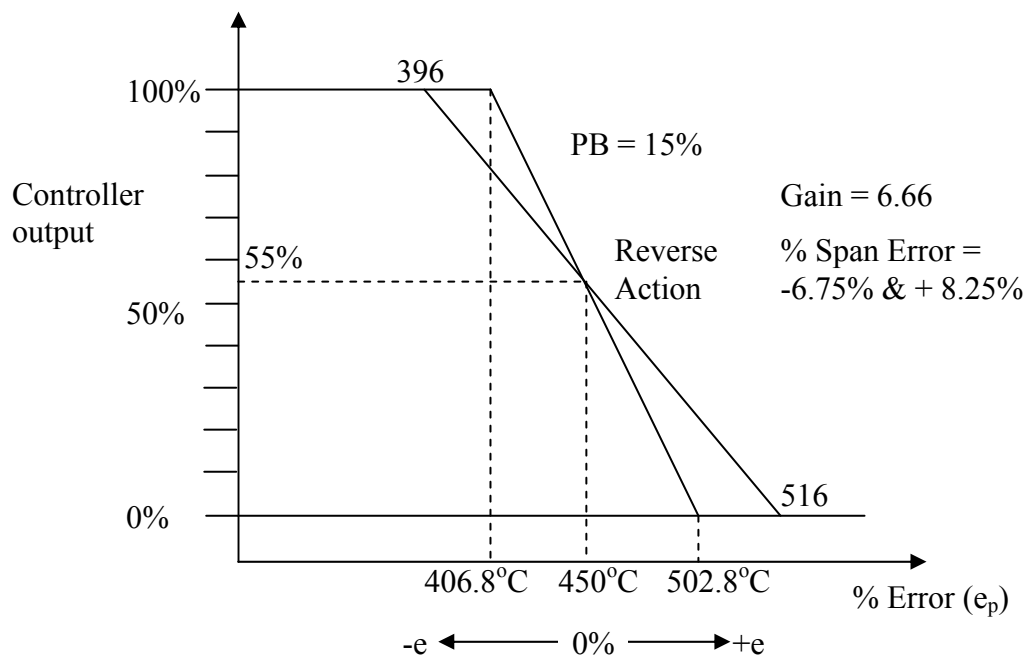

**Example 1.6** An air to open valve on the inflow controls level in a tank. When the process is at the set-point the valve opening is 50%. An increase in outflow results in the valve opening increasing to a new steady state value of 70%. What is the resulting offset if the controller PB is:

- 50%
- 20%

### Solution

To achieve correct control the controller will be reverse action:

- PB = 50%, Gain  $K_p = 2$

Change in valve position =  $70 - 50 = 20\%$

This is the output change from the controller

$$K_p = \frac{\Delta \text{Output}}{\Delta \text{Input}} \Rightarrow \Delta \text{Input} = \frac{\Delta \text{Output}}{K_p} = \frac{20\%}{2} = 10\%$$

Since the controller is reverse acting the measured variable must have been negative, i.e. = -10%. This is equal to a +error, or a –offset, offset = -10% below set point.

- b) PB = 25%,  $K_p = 4$   
 Input = 5%  
 Offset = -5% below SP

## 2. Proportional and Integral Control Action

$$u_{IP} = K_p e + K_I \int edt$$

$$u_{IP} = K_p \left( e + \frac{1}{T_I} \int edt \right)$$

In some controllers, the control signal is computed as:

$$u_{IP} = K_p \left( e + \frac{1}{T_I} \int edt \right) + B \text{ (where B is bias)}$$

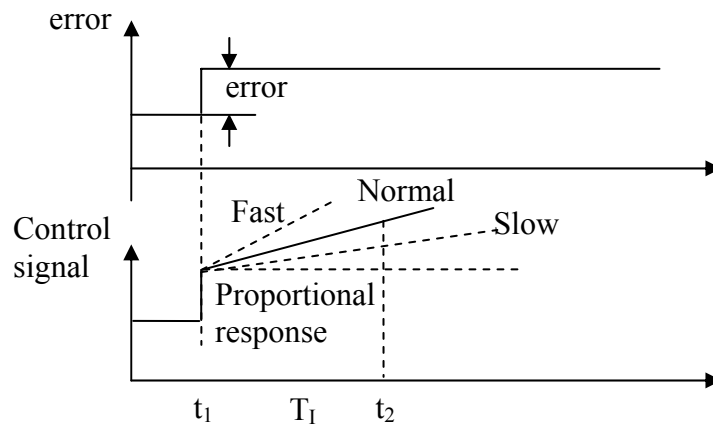

Reset Time = Integral Action Time (IAT) = Minutes/Repeat or Reset Rate = Repeats/Minute

IAT = Infinity – Means no integral action

IAT = 0 – Means infinite integral action

Reset action is defined as either reset rate in repeats per minute (RPM) or reset time in minutes per repeat (MPR):

$$MPR = \frac{1}{RPM}$$

### Example 2.1

A direct acting controller has a proportional band of 50% is subjected to a sustained error. The set point is 50% and the measurement 55%. After 4 minutes, the total output signal from the controller has increased by 30%. What is the reset rate setting in repeats per minute (RPM) and reset time in minutes per repeat (MPR).

### Solution

$$PB = 50\%; K_p = \frac{100\%}{50\%} = 2$$

Due to direct acting,  $K_p$  will be negative

$$\text{Proportional control signal: } V = K_p E = -2 \times (-5\%) = +10\%$$

Total signal after 4 minutes = +30% =  $V_P + V_I$

Integral signal = +20%

i.e. integral action has repeated original proportional gain twice 4 minutes, 2 repeats per 2 minutes or 0.5 repeats per minute.

Reset rate = 0.5 RPM or  $1/0.5$  MPR = 2.0 MPR

### Summary of P+I Control Action

- Reset (Integral) action removes offset
- It's units are Repeats per Minute (RPM) or Minutes per Repeat (MPR)
- If reset action is faster than the process can respond, Reset wind-up can occur.
- Reset Action makes a control loop less stable.

### 3. Proportional and Derivative Control Action

$$u_{PD} = K_p e + K_D \frac{de}{dt} \text{ or}$$

$$u_{PD} = K_p \left( e + T_D \frac{de}{dt} \right)$$

In some controllers, the controller signal is computed as:

$$u_{PD} = K_p \left( e + T_D \frac{de}{dt} \right) + B \text{ (where B is bias)}$$

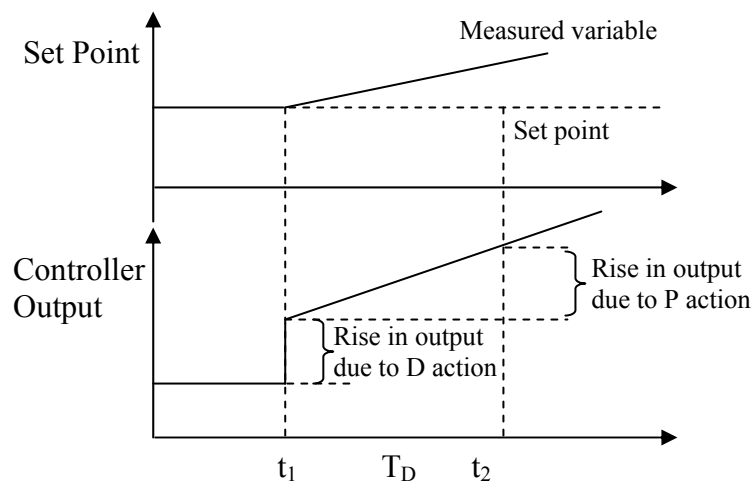

The Derivative Action Time (DAT) is the time taken for the proportional action to repeat the effect of the step change in output due to derivative action alone. Putting it another way: DAT is the time interval by which the effect of the proportional action is advanced.

Units of DAT = Repeats/minute (Rate Time)

DAT = Infinity – Means infinite derivative action (gives ON/OFF control)

DAT = 0 – Means no derivative action (gives proportional control)

### 4. Proportional + Integral + Derivative Control Action

$$u_{PID} = K_p e + K_I \int e dt + K_D \frac{de}{dt} \text{ or}$$

$$u_{PID} = K_p \left( e + \frac{1}{T_I} \int e dt + T_D \frac{de}{dt} \right)$$

In some controllers, the PID control signal is computed as:

$$u_{PID} = K_p \left( e + \frac{1}{T_I} \int e dt + T_D \frac{de}{dt} \right) + B \text{ (where B is bias)}$$

### Exercises

1. What is the gain of a controller with a PB of? a) 40%; b) 200%
2. What is the PB setting in percent for a controller with gain of? a) 3; b) 0.4
3. A temperature controller has the following characteristic curve:

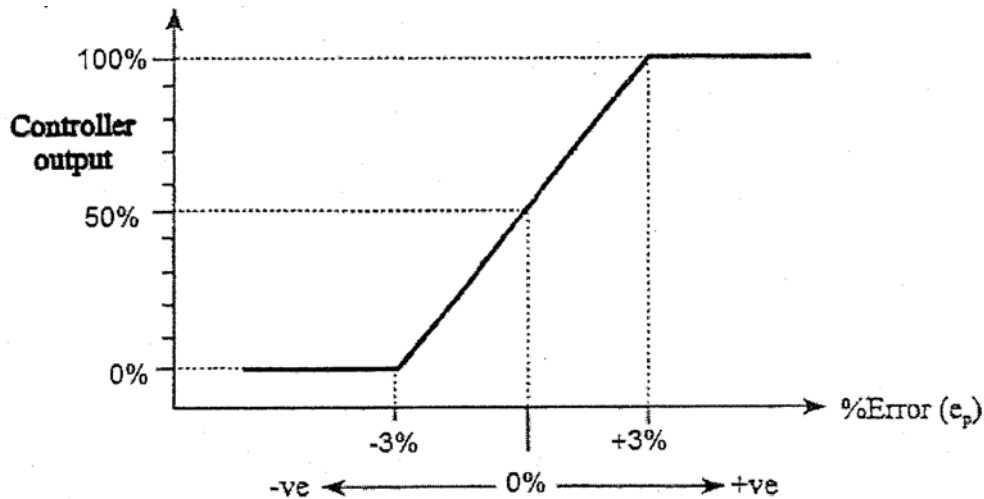

- a) Is the controller set up for heating or cooling?

The controller has a range of 100°C to 400°C. The set-point is 250°C. Calculate:

- b) The controller Proportional Band
  - c) The controller Proportional Gain
  - d) The temperature required to turn the controller's output completely off.
  - e) The temperature required to turn the controller's output fully on.
4. If the proportional band in Example 1.5 was increased to 15%, calculate the span of the proportional band in °C. Using the sample set-point, sketch the relationship between the controller output and % error on the graph in Example 1.5. Does the proportional band decrease or increase in size?
  5. A control system with a direct action controller is operating at the set-point. The controller proportional band is set at 50%. The system is subjected to a disturbance, which creates a positive step error of +6%. The total control output change after 18 minutes is 48%. What is the reset setting in MPR?

**6.** A proportional plus derivative control system is subjected to a ramped error of -10% per minute for 1.5 minutes. The PB setting is 100% and the derivative setting is 3 minutes. The controller is reverse acting. Sketch an open loop response curve for the system showing control signal values at 10% intervals, with respect to time.

**7.** A Direct Acting Proportional Controller is adjusted to a Proportional Band of 50%. In the steady state before a disturbance, the Set-Point is 60 kPa, while the output of the controller is 40 kPa. After a load change, the output of the controller in the resulting steady state is noted to have settled at 60 kPa. Determine the amount of "Offset" that will result from the load change.

**8.** A tank is controlled by an air to close valve on its inflow. When at the set-point the valve opening is 50% an outflow disturbance causes the valve opening to become 80%. The controller's PB setting is 50%. What is the offset (%)? Assume a linear valve characteristic. Remember an air to close valve requires a decrease in signal to open it further.